

XT110C - XT111C - XT114C - XT115C - XT110D - XT111D - XT111R - XT115R

Single Stage Digital Controller For Temperature

CONTENTS:

1. **1. ⚠ GENERAL WARNING** _____ 1
 1.1 Please read before using this manual _____ 1
 1.2 Safety Precautions _____ 1

2. **GENERAL DESCRIPTION** _____ 1

3. **FRONT PANEL COMMANDS** _____ 1
 3.1 Use of LEDS _____ 1

4. **FUNCTION AND PARAMETERS' PROGRAMMING MENU** _____ 2
 4.1 Function Menu _____ 2
 4.2 List of functions _____ 2
 4.3 Exit Timeout _____ 2
 4.4 Accessing "Pr2" and SECURITY CODE input _____ 2
 4.5 Changing a parameter's value _____ 2

5. **LIST OF PARAMETERS** _____ 2
 5.1 Measuring range _____ 2

6. **INSTALLATION AND MOUNTING** _____ 2

7. **ELECTRICAL CONNECTIONS** _____ 3
 7.1 Probes connection _____ 3

8. **ALARM SIGNALS** _____ 3
 8.1 Status of the alarm relay _____ 3
 8.2 Silencing buzzer / alarm relay output _____ 3
 8.3 Alarm recovery _____ 3

9. **TECHNICAL DATA** _____ 3

10. **CONNECTIONS** _____ 3

11. **DEFAULT SETTING VALUES** _____ 5

- Ensure that the wires for probes, loads and the power supply are separated and far enough from each other, without crossing or intertwining.
- In case of applications in industrial environments, the use of mains filters (our mod. FT1) in parallel with inductive loads could be useful.

2. GENERAL DESCRIPTION

The XT110C, XT111C, XT114C, XT115C(32x74 format), XT110D, XT111D (DIN RAIL format) and XT111R, XT115R (72x72 format), are single-stage ON/OFF controllers for temperature applications with direct or inverse action (user-selectable). The analogue input type must be chosen and specified when ordering, according to the process variable to be controlled.

3. FRONT PANEL COMMANDS

SET: By pressing and releasing this key the set point is displayed for 5s.

By holding the key pressed for at least 2s set point change mode is entered: the set point is displayed and the LED1 flashes. To change the value use the "UP" and "DOWN" keys. The new value can be stored either by pressing the "SET" key (the instrument restores temperature display) or by waiting the exit timeout to expire (15s).

TO SWITCH THE INSTRUMENT ON/OFF: If the function is enabled (par. OnF=1), by pressing the SET key for more than 4s the controller is switched OFF. To switch the instrument on again press the SET key.

▲ **(UP)** In programming mode or in "Function Menu" it browses the parameter codes or increases the value of the displayed variable. Hold pressed for a faster change.

▼ **(DOWN)** in programming mode or in "Function Menu" it browses the parameter codes or decreases the value of the displayed variable. Hold pressed for a faster change.

KEY COMBINATIONS:

▲ + ▼ hold pressed for 3s the keyboard is unlocked (see "LOC" function).

SET1 + ▼ When held pressed for 3s the Function Menu is entered.

SET1 + ▲ Programming end, return to the normal display.

3.1 Use of LEDS

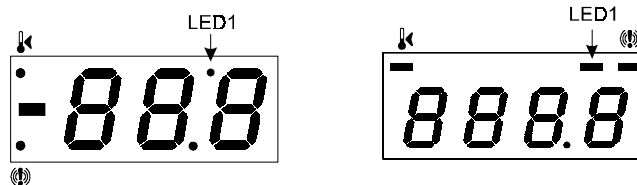

A series of light points on the front panels is used to monitor the loads controlled by the instrument. Each LED function is described in the following table.

LED	MODE	FUNCTION
⏏	ON	Output relay enabled
LED1	FLASHING	- Programming Phase (flashing with LED2)
🔊	ON	- ALARM signal - In "Pr2" indicates the parameter is also present in "Pr1"

1. ⚠ GENERAL WARNING

1.1 Please read before using this manual

- This manual is part of the product and should be kept near the instrument for easy and quick reference.
- The instrument shall not be used for purposes different from those described hereunder. It cannot be used as a safety device.
- Check the application limits before proceeding.

1.2 ⚠ Safety Precautions

- Check the supply voltage is correct before connecting the instrument.
- Do not expose to water or moisture: use the controller only within the operating limits avoiding sudden temperature changes with high atmospheric humidity to prevent formation of condensation
- Warning: disconnect all electrical connections before any kind of maintenance.
- The instrument must not be opened.
- In case of failure or faulty operation send the instrument back to the distributor or to "DIXELL s.r.l." (see address) with a detailed description of the fault.
- Consider the maximum current which can be applied to each relay (see Technical Data).

4. FUNCTION AND PARAMETERS' PROGRAMMING MENU

4.1 Function Menu

Includes all the main functions controlled by the instrument.

Access procedure:

- The menu is entered by holding the **SET** and **DOWN** keys pressed for three seconds. The label of the first function is displayed.
- The **UP** and **DOWN** keys are used to cycle backwards or forward in the menu.
- By pressing the **SET** key the currently displayed function is enabled.

4.2 List of functions

1. "Pr1": includes all user accessible parameters.
2. "Pr2": includes all the instrument's parameters (at installer level). It can be accessed through a security code. Hence it is possible to modify all parameters and add or remove parameters from "Pr1" (user level) by pressing "SET" + "DOWN". When a parameter is enabled at user level, (Alarm LED) is on during programming mode in Pr2.
3. "LOC": keyboard lock. When enabled the "POF" flashing message is displayed for a few seconds then the keys are locked. Only the set point display is enabled.
4. "Out": exits from menu.

4.3 Exit Timeout

If no key is pressed for more than 15 seconds the instrument reverts to normal display mode.

4.4 Accessing "Pr2" and SECURITY CODE input

To access parameters in "Pr2" a security code is required.

1. Enter Function Menu, select label "Pr2" and press the "SET" key. The "PAS" flashing message is displayed, shortly followed by "0 - -" with a flashing zero.
2. Use "UP" or "DOWN" to input the security code in the flashing digit;
3. Confirm the figure by pressing "SET".
4. Repeat operations 2 and 3 for the other digits.
5. If the security code is correct the access to "Pr2" is enabled by pressing "SET" on the last digit, otherwise the security code input process restarts from the beginning.

If no key is pressed for more than 15 seconds the instrument reverts to normal display mode.

SECURITY CODE is 321

NOTE: each parameter in "Pr2" can be removed and put into "Pr1" (user level) by pressing "SET" + "DOWN". When a parameter is present in "Pr1" ALARM LED is on during programming mode in Pr2..

4.5 Changing a parameter's value

Each parameter is identified by a special alphanumeric code.

To change the parameter's value operate as follows:

1. Enter the Function Menu and select the parameters' list you require: "Pr1" or "Pr2".
2. Browse the parameters' list using "UP" or "DOWN" until the required parameter is displayed.
3. Press the "SET" key to display its value.
4. Use "Up" or "DOWN" to change its value.
5. Press "SET" to store the new value and move to the following parameter.

To exit: Press **SET + UP** or wait 15s without hitting a key.

NOTE: the set value is stored even when the procedure is exited by waiting the timeout to expire.

5. LIST OF PARAMETERS

5.1 Measuring range

Probe	Down Scale	Full Scale
PTC	-70.0 °C / -94°F	170.0 °C / 338°F
Pt100	-200 °C / -348 °F	700.0 °C / 1292 °F

Probe	Down Scale	Full Scale
Ni100	-70.0 °C / -94°F	170.0°C / 338 °F
TcK *	-50 °C / -58 °F	1500 °C / 2732 °F
TcJ *	-50 °C / -58 °F	800 °C / 1472 °F
TcS *	-50 °C / -58 °F	1500 °C / 2732 °F

* with 3 digits the max value is 999 or 99.9

Hy1 Differential: (Down Sc./Full Sc.) Intervention differential for set point. It can be set with positive value or with negative value. The kind of action (direct or inverse) depends on the SC1 parameter setting (1 or 0).

LS1 Minimum set point: (Down Sc./ Set) Sets the minimum acceptable value for the set point.

US1 Maximum set point: (Set/ Full Sc.) Sets the maximum acceptable value for set point.

ALU Maximum alarm:

with ALC=0: alarm relative to set point, (0÷|Full Sc.-Set|) Maximum alarm is enabled when the temperature exceeds the "SET+ALU" value.

with ALC=1: absolute alarm, (Set÷Full Sc.) Maximum alarm is enabled when the temperature exceeds the "ALU" value.

ALL Minimum alarm:

with ALC=0: relative to set point, (0÷|Down Sc.-Set|) this value is subtracted from the set point. The alarm signal is enabled when the temperature goes below the "SET-ALL" value.

with ALC=1 (absolute) minimum alarm is enabled when the temperature goes below the "ALL" value.

Ald Alarm delay:(0÷999 min) time interval between the detection of an alarm condition and alarm signalling.

dAO Delay of alarm at start-up: (0÷999 min) time interval between the detection of the alarm condition after instrument power on and alarm signalling.

od Output delay: (0÷500 sec) minimum interval between the load stop and the following restart.

LCI Start of scale with current or voltage input: (3 digit: -999÷999; 4 digit: -999÷7000). Adjustment of read out corresponding to 4mA or 0V input signal.

UCI End of scale with current or voltage input (3 digit: -999÷999; 4 digit: -999÷7000). Adjustment of read out corresponding to 20mA or 1V or 10V input signal.

LAO Lower analog output limit: (only for models with analog output) minimum value of temperature associated to the 4mA (or 0V) analog output. This value can be absolute or relative to the Set Point 1 by setting the AOC parameter.

UAO Upper analog output limit: (only for models with analog output) maximum value of temperature associated to the 20mA (or 5V) analog output. This value can be absolute or relative to the Set Point 1 by setting the AOC parameter.

OPb Probe calibration: (-999÷999) allows to adjust possible offset of the probe.

Ad1..Ad2: RS485 serial address (0÷94): identifies the instrument within a control or supervising system.

PbC Probe selection: input type. For RTD or Thermocouples only: 0=Tc J; 1=Tc K (Ni100); 2=Tc S (Pt100).

AOC Analog output configuration:

AOC=0 Probe reading. The analog output parameters LAO and UAO are independent and correspond to the absolute read-out probe signal.

AOC=1 Probe-Set Point. the analog output parameters LAO and UAO are related to the Set Point 1.

So1 Relay status with faulty probe:

So1=0 open; So1=1 close.

Hdd Half digit display: (Hdd=0 OFF; Hdd=1 ON)the right hand digit can be set to read out only 0 or 5, or to read out all values from 0 to 9.

E.g. if **Hdd= 0** the displayed values could be: 231, 232, 233...

if **Hdd= 1** the displayed values could be 230, 235, 240...

rES Decimal point ON/OFF: (rES=0 OFF; rES=1 ON) select the resolution of the controller: with decimal point or without decimal point.

NOTE1: on all models, if a unit is changed from "without decimal point" into "with decimal point", all parameters values

expressed in degrees (**SET, HY1, LS1, US1, ALU, ALL, LCI, UCI, LAO, UAO, OPb**) will automatically be **divided by 10**.
To restore the right behaviour multiplie by 10 the above parameters.

NOTE2: the decimal point selection is not available on models with thermocouple input.

CF Temperature measurement unit
 0 = Celsius; 1 = Fahrenheit.

ALC Set point alarms configuration:
 (0= relative to set point; 1=absolute) determines if alarms are relative to set point or referred to absolute values.

SAO Analog output safety with probe fault (only for models with analog output): determines what state the analog output should assume when the probe is faulty: SAO = 0; analog output = 20mA or 1Vdc. SAO = 1; analog output = 4mA or 0Vdc.

OnF Switching ON/OFF enabling from keyboard: (0 = disabled; 1=enabled) It permits the switching ON/OFF of the instrument by pressing the SET key for more than 4s.

Ptb Parameters table: (read only) Shows the factory default settings.

rEL Software release: (read only)

6. INSTALLATION AND MOUNTING

Instruments **XT110C, XT111C, XT114C, XT115C** are panel mounted, in a 29x71 mm hole, and fixed using the special bracket supplied.

Instruments **XT110D, XT111D**, shall be mounted on an omega DIN rail (3).

Instruments **XT111R, XT115R** are panel mounted, in a 68x68 mm hole, and fixed using the special bracket supplied.

The ambient temperature range allowed for correct operation is 0÷60 °C. Avoid places subject to strong vibrations, corrosive gases, excessive dirt or humidity. Let air circulate through the ventilation holes.

7. ELECTRICAL CONNECTIONS

The instruments are provided with screw terminal block to connect cables with a cross section up to 2,5 mm². Before connecting cables make sure the power supply complies with the instrument's requirements. Separate the input connection cables from the power supply cables, from the outputs and the power connections. Do not exceed the maximum current allowed on each relay, in case of heavier loads use a suitable external relay.

7.1 Probes connection

The PTC probes shall be mounted with the bulb upwards to prevent damages due to casual liquid infiltration.

8. ALARM SIGNALS

Message - Mode	Cause	Outputs
"ooo" Flashing	Probes break or absence	Alarm output ON; Relay output according to parameters "So1"
"CCC" Flashing	Probe shorted circuit	Alarm output ON; Relay output according to parameters "So1"
"HA" Alternating with normal display	Maximum temperature alarm	Alarm output ON; Other outputs unchanged.
"LA" Alternating with normal display	Minimum temperature alarm	Alarm output ON; Other outputs unchanged.

8.1 Status of the alarm relay

MODE	RELAY STATUS
Instrument OFF	Closed
Normal operating mode	Open
Alarm occurring	Closed

8.2 Silencing buzzer / alarm relay output

Once the alarm signal is detected the buzzer and the alarm output can be disabled by pressing any key. The display signal remains as long as the alarm condition remains.

8.3 Alarm recovery

Probe alarms "ooo", "CCC" start 30 seconds after the fault in the probe; they automatically stop 30 seconds after the probe restarts normal operation. Check connections before replacing the probe.

Max. and min. alarms "HA" and "LA" automatically stop as soon as the variable returns to normal values.

9. TECHNICAL DATA

Housing: self extinguishing ABS.

Case:

XT110C, XT111C, XT114C, XT115C frontal 32x74 mm; depth 60mm;

XT110D, XT111D: 4 DIN modules 70x85 mm; depth 61mm.

XT111R, XT115R: frontal 72x72, depth 100mm

Mounting:

XT110C, XT111C, XT114C, XT115C panel mounting in a 71x29 mm panel cut-out.

XT110D, XT111D: DIN RAIL

XT111R, XT115R: panel mounting in a 68x68mm panel cut-out.

Frontal protection

XT110C, XT111C, XT114C, XT115C, XT111R, XT115R IP65

Connections: Screw terminal block ≤ 2,5 mm² wiring.

Power supply:

XT110C, XT111C, XT114C, XT115C 12Vac/dc, -10% +15% 50/60Hz. (optional 24Vac/dc)

XT110D, XT111D, XT111R, XT115R:110/230Vac, ±10% 50/60Hz (optional 24Vac, ±10% 50/60Hz)

Power absorption:

XT110C, XT111C, XT110D, XT111D, XT111R: 3VA max.

XT114C, XT115C, XT115R: 5VA max

Display

XT110C, XT111C, XT110D, XT111D, XT111R: 3 digits, red LED, 14,2 mm high.

XT114C, XT115C, XT115R: 4 digits, red LED, 12,5 mm high.

Inputs: according to the order: PTC or Pt100 or Thermocouple (J, K, S) or 4÷20mA or 0÷1V or 0÷10V

Relay outputs:

Load

XT110C, XT111C, XT114C, XT115C:SPST relay, 8(3)A, 250Vac

XT110D, XT111D:SPST relay, 5(2)A, 250Vac

XT111R, XT115R:SPDT relay, 8(3)A, 250Vac

Alarm

XT111C, XT115C, XT111D, XT111R, XT115R: SPST relay, 8(3)A, 250Vac

Other output: **XT111C, XT115C, XT111D, XT111R, XT115R:** buzzer for acoustical alarm

Data storing: on the non-volatile memory (EEPROM).

Operating temperature: 0÷60 °C (32÷140°F).

Relative humidity: 20÷85% (no condensing)

Storage temperature: -30÷85 °C (-22÷185°F).

Measuring range: according to the probe

Controller Accuracy at 25°C: better than ±0,5% of full scale

10. CONNECTIONS

XT110C, XT114C

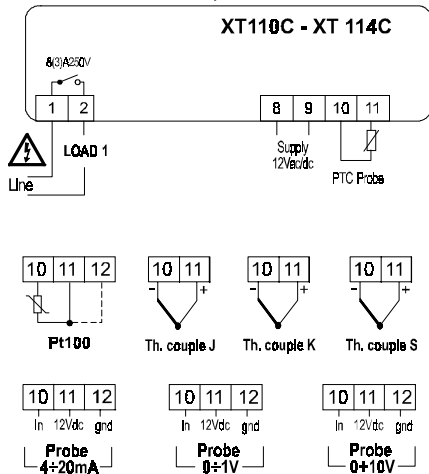

Power supply 24Vac/dc: connect to the terminals 8-9
 Pt100 with 2 wires: the terminals 11 and 12 must be shorted circuit.

XT111C, XT115C

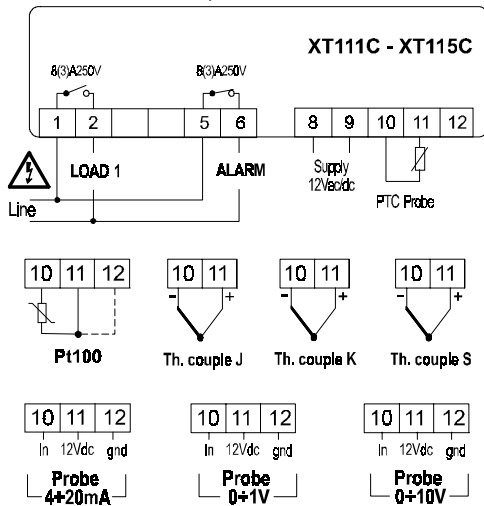

Power supply 24Vac/dc: connect to the terminals 8-9
 Pt100 with 2 wires: the terminals 11 and 12 must be shorted circuit.

XT110D

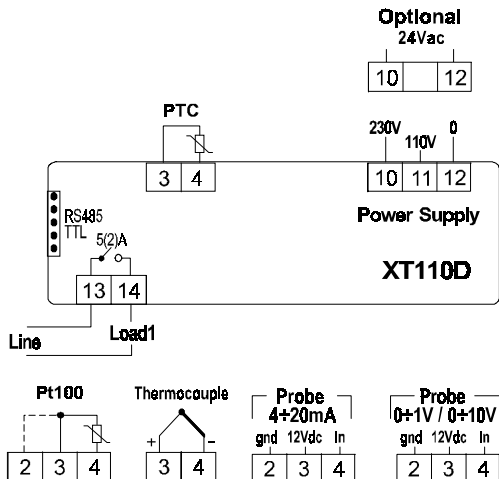

Power supply 24Vac/dc: connect to the terminals 10-12
 Pt100 with 2 wires: the terminals 2 and 3 must be shorted circuit.

XT111D

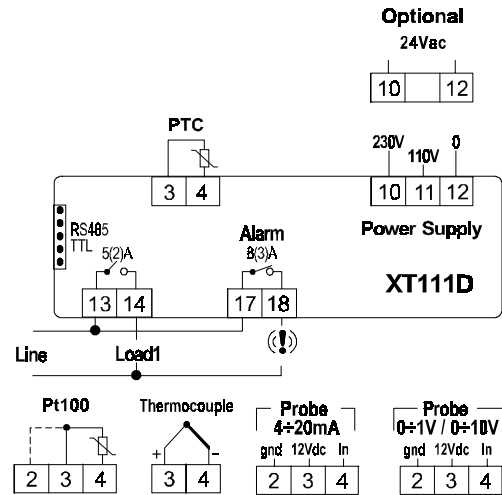

Power supply 24Vac/dc: connect to the terminals 10-12
 Pt100 with 2 wires: the terminals 2 and 3 must be shorted circuit.

XT111R, XT115R (no RS485)

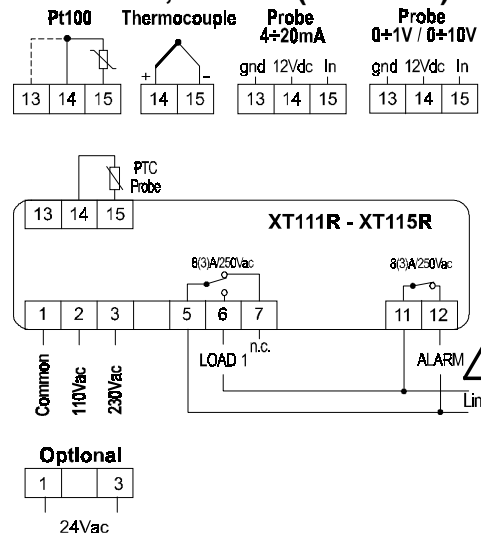

Pt100 with 2 wires: short circuit the terminals 13 and 14

XT111R, XT115R (with RS485)

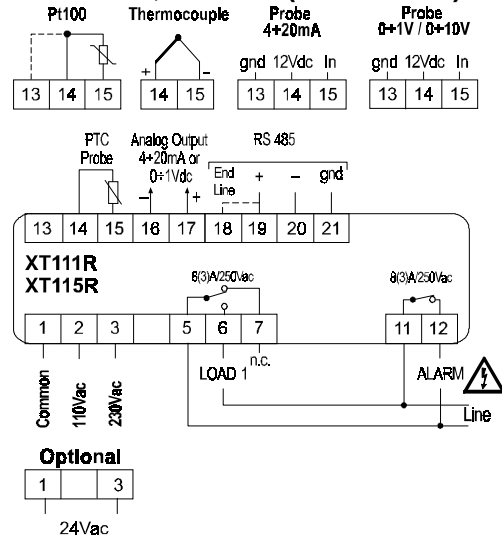

Pt100 with 2 wires: short circuit the terminals 13 and 14

11. DEFAULT SETTING VALUES

COD	RANGE	Level	Def. Value
Set	LS1÷US1	Pr1	0/32
Hy1	Down Sc./ Full Sc.	Pr1	-1/-2
LS1	Down Sc./ Set	Pr2	min
US1	Set./ Full Sc.	Pr2	max
ALU	0÷ Full Sc.-set	Pr2	10/18
ALL	0÷ Down Sc.-set	Pr2	10/18
Ald	0÷999 min	Pr2	15
dAO	0÷999 min	Pr2	30
od	0÷500 sec	Pr2	0
LC 1	According to the probe	Pr2	various
UC 1	According to the probe	Pr2	various
LAO2	Down Sc./ Full Sc.	Pr2	min
UAO2	Down Sc./ Full Sc.	Pr2	max
OPb	Down Sc./ Full Sc.	Pr2	0
Ad1..A d2	RS485 address	Pr2	0..1
PbC3	0=Tc J 1=Tc K (Ni100) 2=Tc S (Pt100)	Pr2	-
AOC2	0=Probe; 1=Prebe-set	Pr2	0
S1C	0=heating 1=Cooling	Pr2	0
So1	0=open 1=closed	Pr2	0
Hdd	0=OFF 1=ON	Pr2	0
rES	0=OFF 1=ON	Pr2	0
CF	0=Celsius 1= Farehnehit	Pr2	0/1
ALC	0= relative 1= absolute	Pr2	0
SAO2	0=min; 1=max	Pr2	0
OnF	0=not enabled; 1=enabled	Pr2	0
Ptb	---	Pr2	various
rEL	---	Pr2	0.4

¹ with current or voltage input

² only on models with analog output

³ with thermocouple or RTD input

Dixell s.r.l. Z.I. Via dell'Industria, 27
 32010 Pieve d'Alpago (BL) ITALY
 tel. +39 - 0437 - 98 33 - fax +39 - 0437 - 98 93 13
 E-mail: dixell@dixell.com - <http://www.dixell.com>