

XR160C - XR160D - XR170C - XR170D - XR162C - XR172C**CONTENTS**

1. GENERAL WARNING	2
1.1 Please read before using this manual	2
1.2 Safety Precautions	2
2. GENERAL DESCRIPTION	2
3. CONTROLLING LOADS	2
3.1 The compressor	2
3.2 Fast freezing	3
3.3 Defrost	3
3.4 "Air dryer" applications	3
3.5 Control of evaporator fans	3
3.6 Fan relay used as 2° compressor	3
4. FRONT PANEL COMMANDS	3
4.1 Use of LEDS	4
5. FUNCTION AND PARAMETERS' PROGRAMMING MENU	4
5.1 Function Menu	4
5.2 List of functions	4
5.3 Exit Timeout	4
5.4 Accessing "Pr2" and SECURITY CODE input	5
5.5 Changing a parameter's value	5
6. LIST OF PARAMETERS	5
7. INSTALLATION AND MOUNTING	6
8. ELECTRICAL CONNECTIONS	6
8.1 Probes connection	6
9. ALARM SIGNALS	7
9.1 Silencing buzzer / alarm relay output	7
9.2 Alarm "EE"	7
9.3 Alarm reset through keyboard	7
9.4 Alarm recovery	7
10. TECHNICAL DATA	7
11. CONNECTIONS	8
12. DEFAULT SETTING VALUES - STANDARD MODELS	9

1. GENERAL WARNING

1.1 Please read before using this manual

- This manual is part of the product and should be kept near the instrument for easy and quick reference.
- The instrument shall not be used for purposes different from those described hereunder. It cannot be used as a safety device.
- Check the application limits before proceeding.

1.2 Safety Precautions

- Check the supply voltage is correct before connecting the instrument.
- Do not expose to water or moisture: use the controller only within the operating limits avoiding sudden temperature changes with high atmospheric humidity to prevent formation of condensation
- Warning: disconnect all electrical connections before any kind of maintenance.
- The instrument must not be opened.
- Fit the probe where it is not accessible by the End User.
- In case of failure or faulty operation send the instrument back to the distributor or to **dixell** s.r.l (see address) with a detailed description of the fault.
- Consider the maximum current which can be applied to each relay (see Technical Data).
- Ensure that the wires for probes, loads and the power supply are separated and far enough from each other, without crossing or intertwining.
- In case of applications in industrial environments, the use of mains filters (our mod. FT1) in parallel with inductive loads could be useful.

2. GENERAL DESCRIPTION

Models **XR160C** and **XR170C**, 32x74 mm format, are microprocessor based controllers suitable for applications on medium or low temperature refrigerating units. They are provided with three relay outputs to control compressor, defrost - which can be either electrical or hot gas - and the evaporator fans. They are also provided with two PTC probe inputs, one for temperature control, the other to be located onto the evaporator to control the defrost termination temperature.

Model **XR170C** also features an additional relay for the alarm output and an internal buzzer for acoustic signal.

Models **XR160D** and **XR170D**, DIN RAIL format, provide the same features as the correspondent **XR160C** and **XR170C** models. Alarm conditions in model XR160D are also signalled by a 12V/40mA output.

Models **XR162C** and **XR172C**, matched with slave devices **XR30SL** and **XR40SL** respectively, provide the same features as **XR160C** and **XR170C**.

Each instrument is fully configurable through special parameters that can be easily programmed through the keypad.

3. CONTROLLING LOADS

3.1 The compressor

The regulation is performed according to the temperature measured by the thermostat probe with a positive differential from the set point: if the temperature increases and reaches set point plus differential the compressor is started and then turned off when the temperature reaches the set point value again.

In case of fault in the thermostat probe the start and stop of the compressor are timed through parameters "COn" and "COF".

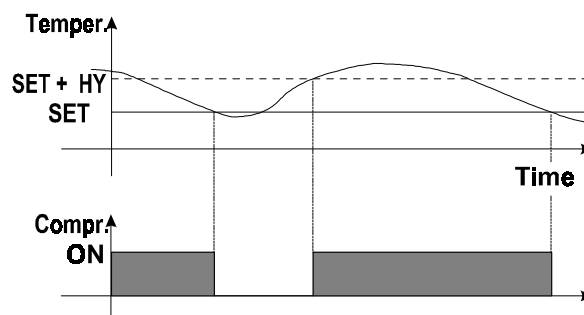

3.2 Fast freezing

When defrost is not in progress, it can be activated the keypad by holding the “UP” key pressed for about 3 seconds. The compressor operates in continuous mode for the time set through the “Cct” parameter. The cycle can be terminated before the end of the set time using the same activation key, “UP” for about 3 seconds.

3.3 Defrost

Two defrost modes are available through the “tdF” parameter: defrost through electrical heater (tdF = 0) and hot gas defrost (tdF = 1). Other parameters are used to control the interval between defrost cycles and its maximum length. The defrost end is controlled by the evaporator’s probe.

At the end of defrost the drip time starts - it is controlled through the “Fdt” parameter.

3.4 “Air dryer” applications

The tdF parameter can be set also for “Air dryer” applications. In this case (tdF=2 or 3) the defrost relay is energised according to the “Short Time” mode. The following parameter table describes the cycle times when the tdF parameter is selected for Long or Short time.

Parameters	Long time (tdF = 0; 1)	Short time (tdF = 2; 3)
dAF, dSd, MdF, Fdt	minutes	seconds
ldF	hours	minutes

3.5 Control of evaporator fans

The fan control mode is selected by means of the “FnC” parameter:

FnC=0 fans will switch ON and OFF with the compressor and **not run** during defrost;

FnC=1 fans will run continuously, but not during defrost

After defrost, there is a timed fan delay allowing for drip time, set by means of the “Fnd” parameter.

FnC=2 fans will switch ON and OFF with the compressor and **run** during defrost;

FnC=3 fans will run continuously also during defrost

An additional parameter “FSt” provides the setting of temperature, detected by the evaporator probe, above which the fans are always OFF. This can be used to make sure circulation of air only if his temperature is lower than set in “FSt”.

3.6 Fan relay used as 2° compressor

If **FnC=4** the fan relay is programmed to control a second compressor, in this case the **Fnd** parameter value is defined as time delay, in seconds, between turning on compressors 1 and 2.

4. FRONT PANEL COMMANDS

SET: **TO DISPLAY TARGET SET POINT:** by pressing and releasing this key the set point is displayed for 5s.

TO MODIFY SET POINT: by holding the key pressed for at least 2s set point change mode is entered: the set point is displayed and the LEDs of the first and third digits blink. To change the value use the “UP” and “DOWN” keys. The new value can be stored either by pressing the “SET” key (the instrument restores temperature display) or by waiting the exit time-out to expire (15s).

▲ (UP): in programming mode or in “Function Menu” it browses the parameter codes or increases the value of the displayed variable. Hold pressed for a faster change.

TO START A FAST FREEZING CYCLE: in normal operation, by holding it pressed for 3s the fast freezing cycle is started. Such cycle can be interrupted by holding the “UP” key pressed for 3s.

▼ (DOWN): in programming mode or in “Function Menu” it browses the parameter codes or decreases the value of the displayed variable. Hold pressed for a faster change.



TO START A MANUAL DEFROST: by holding it pressed for 3s the defrost cycle is started

KEY COMBINATIONS:

- ▲+ ▼** **TO UNLOCK THE KEYBOARD:** when held pressed for 3s the keyboard is unlocked (see "LOC" function).
- SET + ▼** **TO ENTER ON FUNCTION MENU:** when held pressed for 3s the Function Menu is entered.
- SET + ▲** **TO RETURN TO THE ROOM TEMPERATURE DISPLAY:** programming end, return to the room temperature display.

4.1 Use of LEDs

A series of light points on the front panels is used to monitor the loads controlled by the instrument. Each LED function is described in the following table.



LED	MODE	Function
	ON	Compressor enabled
	FLASHING	- Programming Phase (flashing with LED) - Anti-short cycle delay enabled
	ON	Fan enabled
	FLASHING	Programming Phase (flashing with LED)
	ON	Defrost enabled
	FLASHING	Drip time in progress
	ON	Fast freezing enabled
Alarm	ON	- ALARM signal - In "Pr2" indicates the parameter is also present in "Pr1"

5. FUNCTION AND PARAMETERS' PROGRAMMING MENU

5.1 Function Menu

Includes all the main functions controlled by the instrument.

Access procedure:

- The menu is entered by holding the **SET** and **DOWN** keys pressed for three seconds. The label of the first function is displayed.
- The **UP** and **DOWN** keys are used to cycle backwards or forward in the menu.
- By pressing the **SET** key the currently displayed function is enabled.

5.2 List of functions

1. "dFt": displays for 5s the time to defrost [hours].
2. "Pt2": displays for 5s the temperature of the second probe.
3. "Pr1": includes all user accessible parameters.
4. "Pr2": includes all the instrument's parameters (at installer level). It can be accessed through a security code. Hence it is possible to modify all parameters and add or remove parameters from "Pr1" (user level) by pressing "**SET**" + "**DOWN**". When a parameter is enabled at user level, LED (Alarm LED) is on.
5. "LOC": keyboard lock. When enabled the "POF" flashing message is displayed for a few seconds then the keys are locked. Only the set point display is enabled.
6. "Out": exits from menu.

From functions "dFt" and "Pt2" the instrument will go back to "Functions Menu" by time out. From the all other functions the instrument will display again the room temperature by time out.

5.3 Exit Timeout

If no key is pressed within 15 seconds the instrument switches back to room temperature display mode.

5.4 Accessing “Pr2” and SECURITY CODE input

To access parameters in “Pr2” a security code is required.

1. Enter Function Menu, select label “Pr2” and press the “SET” key. The “PAS” flashing message is displayed, shortly followed by “0 - -” with a flashing zero.
2. Use “UP” or “DOWN” to input the security code in the flashing digit;
3. Confirm the figure by pressing “SET”.
4. Repeat operations 2 and 3 for the other digits.
5. If the security code is correct the access to “Pr2” is enabled by pressing “SET” on the last digit, otherwise the security code input process restarts from the beginning.

If no key is pressed within 15 seconds the instrument reverts to room temperature display mode.

SECURITY CODE is 321

NOTE: each parameter in “Pr2” can be removed or put into “Pr1” (user level) by pressing “SET” + “DOWN”.

When a parameter is present in “Pr1” LED  is on.

5.5 Changing a parameter’s value

Each parameter is identified by a special alphanumeric code (label).

To change the parameter’s value operate as follows:

1. Enter the Function Menu and select the parameters’ list you require: “Pr1” or “Pr2”.
2. Browse the parameters’ list using “UP” or “DOWN” until the required parameter is displayed.
3. Press the “SET” key to display its value.
4. Use “UP” or “DOWN” to change its value.
5. Press “SET” to store the new value and skip to the following parameter.

TO EXIT: Press “SET”+“UP” or wait 15s without pressing a key.

NOTE: the set value is stored even when the procedure is exited by waiting the timeout to expire.

6. LIST OF PARAMETERS

Hy Differential: (0,2°C ÷ 12,0°C / 2°F ÷120°F) Intervention differential for set point, always positive. Compressor Cut IN is Set Point Plus Differential (Hy). Compressor Cut OUT is when the temperature reaches the set point.

LS Minimum set point: (-57°C÷SET/-57°F÷SET): Sets the minimum acceptable value for the set point.

US Maximum set point: (SET÷99°C/SET÷196°F). Set the maximum acceptable value for set point.

AC Anti-short cycle delay: (0÷30 min) minimum interval between the compressor stop and the following restart.

ALC Temperature alarms configuration: (0 = temperature alarm are related to SET, alarm relay and buzzer works in parallel; 1 = temperature alarms are referred to absolute values; alarm relay and buzzer work in parallel; 2= referred to set, alarm relay is active when the alarm is active; 3= absolute temperature, alarm relay is active when the alarm is active) determines if temperature alarms are referred to set point or if alarms are referred to absolute temperatures.

ALU MAXIMUM temperature alarm: (with **ALC = 0** or **2**, from 0 to 50°C/90°F; with **ALC = 1** or **3**, from ALL÷99°C/196°F) when this temperature is reached the alarm is enabled, after the ALd delay time.

ALL Minimum temperature alarm: (with **ALC = 0** or **2**, from 0 to 50°C/90°F; with **ALC = 1** or **3**, from -57°C/°F to ALU) when this temperature is reached the alarm is enabled, after the ALd delay time.

ALd Temperature alarm delay: (0÷120 min) time interval between the detection of an alarm condition and alarm signalling.

dAO Delay of temperature alarm at startup: (from 0 min to 720 min; res. 10min) time interval between the detection of the temperature alarm condition after instrument power on and alarm signalling.

OdS Outputs activation delay at start up: (0÷120min) This function is enabled at the initial start up of the instrument and inhibits any output activation for the period of time set in the parameter.

CCt Compressor ON time during fast freezing: (0÷990min; res. 10 min) allows to set the length of the continuous cycle. Can be used, for instance, when the room is filled with new products.

dAF Defrost delay after fast freezing: (with tdF=0 or 1: 0÷120min; with tdF=2 or 3: 0÷120sec) time interval between the end of the fast freezing and the following defrost related to it.

IdF Interval between defrost cycles: (with tdF=0 or 1: 0÷120h; with tdF=2 or 3: 0÷120min) Determines the time interval between the beginning of two defrost cycles.

dSd Start defrost delay:(with tdF=0 or 1: 0÷59min; with tdF=2 or 3: 0÷59sec) This is useful when different defrost start times are necessary to avoid overloading the plant.

- MdF (Maximum) length for defrost:**(with tdF=0 or 1: 0÷120min; with tdF=2 or 3: 0÷120sec) When **EdF = 0**, (not evaporator probe: timed defrost) it sets the defrost duration, when **EdF = 1** (defrost end based on temperature) it sets the maximum length for defrost.
- dtE Defrost termination temperature:** (-57 ÷ 99°C/-57÷196°F) (Enabled only when EdF=1) sets the temperature measured by the evaporator probe, which causes the end of defrost.
- dFd Temperature displayed during defrost:** (0 = real temperature; 1 = temperature at defrost start; 2 = set point; 3 = "dEF" label)
- dAd MAX display delay after defrost:** (0÷120 min). Sets the maximum time between the end of defrost and the restarting of the real room temperature display.
- tdF Defrost type:** (0 = electrical heater, long time; 1 = hot gas, long time; 2=OFF compressor, short time; 3= ON compressor, short time)
- EdF Evaporator probe presence:** (0 = Not present: timed defrost end; 1=present: defrost end based on temperature)
- Fdt Drain time:** (with tdF=0 or 1: 0÷120min; with tdF=2 or 3: 0÷120sec) time interval between reaching defrost termination temperature and the restoring of the control's normal operation. This time allows the evaporator to eliminate water drops that might have formed due to defrost.
- dPO First defrost after startup:** (0 = Immediately; 1 = after the IdF time)
- FnC Fan operating mode:** (0 = runs with the compressor, OFF during defrost; 1 = continuous mode, OFF during defrost; 2 = runs with the compressor, ON during defrost; 3 = continuous mode, ON during defrost; 4 = fan relay is used as 2° compressor output)
- FSt Fan stop temperature:** (-57÷99°C/196°F) setting of temperature, detected by evaporator probe, above which the fan is always OFF.
- Fnd Fan delay after defrost:** (with tdF=0 or 1: 0÷120min; with tdF=2 or 3: 0÷120sec) The time interval between end of defrost and evaporator fans start.
- Ot Thermostat probe calibration:** (-12.0÷12.0°C; -120÷120°F) allows to adjust possible offset of the thermostat probe.
- OE Evaporator probe calibration:** (-12.0÷12.0°C; -120÷120°F) allows to adjust possible offsets of the evaporator probe.
- CF Temperature measurement unit:** 0 = Celsius; 1 = Fahrenheit.
WARNING: When the measurement unit is changed the SET point and the values of the parameters Hy, LS, US, ALU, ALL, dtE, FSt, Ot and OE have to be modified
- COnc Compressor ON time with faulty probe** (0÷120 min) time during which the compressor is active in case of faulty thermostat probe. With COnc=0 compressor is always OFF.
- COF Compressor OFF time with faulty probe** (0÷120 min) time during which the compressor is off in case of faulty thermostat probe. With COF=0 compressor is always active.

7. INSTALLATION AND MOUNTING

Instruments **XR160C**, **XR170C**, **XR162C** and **XR172C** shall be mounted on panel, in a 29x71 mm hole, and fixed using the special bracket supplied. **XR160D**, **XR170D** and slave modules **XR30SL** and **XR40SL** shall be mounted on an omega DIN rail. The instruments provided with a slave module shall be connected through the special multipolar cable supplied.

The temperature range allowed for correct operation is 0 - 60 °C. Avoid places subject to strong vibrations, corrosive gases, excessive dirt or humidity. The same recommendations apply to probes. Let air circulate by the cooling holes.

8. ELECTRICAL CONNECTIONS

The instruments are provided with screw terminal block to connect cables with a cross section up to 2,5 mm². Before connecting cables make sure the power supply complies with the instrument's requirements. Separate the probe cables from the power supply cables, from the outputs and the power connections. Do not exceed the maximum current allowed on each relay, in case of heavier loads use a suitable external relay.

Instruments **XR162C** and **XR172C** are connected to slave modules **XR30SL** and **XR40SL**, respectively, through a multipolar connector (included). They accommodate the instrument relays and the transformer powering the whole system.

8.1 Probes connection

The probes shall be mounted with the bulb upwards to prevent damages due to casual liquid infiltration. It is recommended to place the thermostat probe away from air streams to correctly measure the average room temperature. Place the defrost termination probe among the evaporator fins in the coldest place, where most

ice is formed, far from heaters or from the warmest place during defrost, to prevent premature defrost termination.

9. ALARM SIGNALS

Message - Mode	Cause	Outputs
"EE" Flashing	Data or memory failure	Alarm output ON; Other outputs unchanged
"P1" Flashing	Thermostat probe failure	Alarm output ON; Compressor output according to parameters "CO _n " and "CO _F "
"P2" Alternating with room temperature	Evaporator probe failure	Alarm output ON; Other outputs unchanged; End defrost is timed
"HA" Alternating with room temperature	Maximum temperature alarm	Alarm output ON; Other outputs unchanged.
"LA" Alternating with room temperature	Minimum temperature alarm	Alarm output ON; Other outputs unchanged.
"dEA" Alternating with room temperature	Defrost timeout alarm	Alarm output ON; Other outputs unchanged.
"FF" Alternating with room temperature	Fast freezing interrupted by power failure	Alarm output ON; Other outputs unchanged.

9.1 Silencing buzzer / alarm relay output

Once the alarm signal is detected the buzzer and the alarm output can be disabled by pressing any key according to the ALC par.

With ALC=0 or 1 buzzer and alarm relay are silenced by pressing any key

With ALC=2 or 3 the buzzer is silenced by pressing a key, the alarm relay remains activated as long as the alarm condition lasts.

The display signal remains as long as the alarm condition remains.

9.2 Alarm "EE"

The instruments in the Dixell range are provided with an internal check verifying data and memory integrity. Alarm "EE" flashes when a failure in data or in the internal memory is detected. In such case the alarm output is enabled.

WHAT TO DO

1. Cancel the alarm by pressing a key.
2. Check the value of all parameters and restore correct values when wrong.
3. Check the correct instrument operation and in case of further errors replace it.

9.3 Alarm reset through keyboard

It is referred to alarms "EE", "dEA" and "FF". Reset is performed by pressing any key while the alarm is being signalled, then message "rES" is displayed for about 3s before normal operation is restored.

9.4 Alarm recovery

Probe alarms "P1" and "P2" start 30 seconds after the fault in the related probe; they automatically stop 30 seconds after the probe restarts normal operation. Check connections before replacing the probe.

Temperature alarms "HA" and "LA" automatically stop as soon as the thermostat temperature returns to normal values and when defrost starts.

Alarms "dEA" and "FF" automatically stop after 30 minutes.

10. TECHNICAL DATA

Housing: self extinguishing ABS.

Case

XR160C, XR162C, XR172C: frontal 32x74 mm; depth 60mm;

XR170C: frontal 32x74 mm; depth 70mm

XR160D, XR170D, XR30SL, XR40SL: 4 DIN modules 70x85 mm; depth 61mm.

Mounting

XR160C, XR170C, XR162C, XR172C panel mounting in a 71x29 mm panel cut-out.

XR160D, XR170D, XR30SL, XR40SL: DIN RAIL mounted in a omega (3) din rail .

Frontal protection

XR160C, XR170C, XR162C, XR172C: IP65

Connections: Screw terminal block $\leq 2,5 \text{ mm}^2$ wiring.

XR162C is connected to the slave module **XR30SL** through a multipolar connector.

XR172C is connected to the slave module **XR40SL** through a multipolar connector.

Power supply

XR160C, XR170C: 12Vac/dc, -10% +15%.

XR160D, XR170D, XR30SL, XR40SL: 110/230Vac, $\pm 10\%$ 50/60Hz (opt. 24Vac, $\pm 10\%$ 50/60Hz).

XR162C: by the slave XR30SL.

XR172C: by the slave XR40SL.

Power absorption: 3VA max.

Display: 3 digits, red LED, 14,2 mm high.

Inputs: 2 PTC probes.

Relay outputs

compressor

XR160C, XR170C, XR160D, XR170D: SPDT relay 8(3)A, 250Vac

XR162C, XR172C SPST relay 16(6)A, 250Vac

defrost

XR160C, XR170C, XR162C, XR172C: SPDT relay 8(3) A, 250Vac

XR160D, XR170D: SPST relay 5(2)A, 250Vac

fans

XR160C, XR170C, XR162C, XR172C: SPST 8(3)A, 250Vac

XR160D, XR170D: SPST relay 5(2)A, 250Vac

alarm

XR170C, XR172C: SPDT relay 8(3) A, 250Vac

XR170D: SPST relay 5(2)A, 250Vac

Other output

XR160D, XR162C: alarm output 12V/40mA

XR160C, XR170C, XR160D, XR170D, XR172C: buzzer for an acoustic signal of alarms

Data storing: on the non-volatile memory (EEPROM).

Operating temperature: 0÷60 °C.

Relative humidity: 20÷85% (no condensing)

Storage temperature: -30÷85 °C.

Measuring and regulation range: -55÷99 °C / -57÷196 °F

Resolution: 0,1 °C or 1 °F (selectable).

Accuracy of the controller at 25°C: range -40÷50°C (-40÷122°F): $\pm 0,3 \text{ °C} \pm 1 \text{ digit}$

11. CONNECTIONS

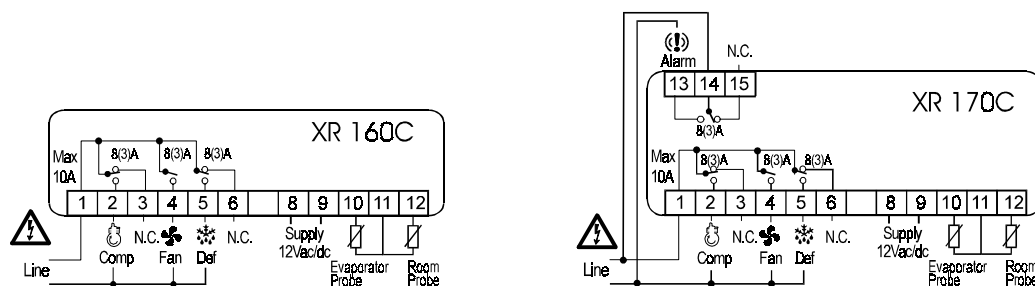

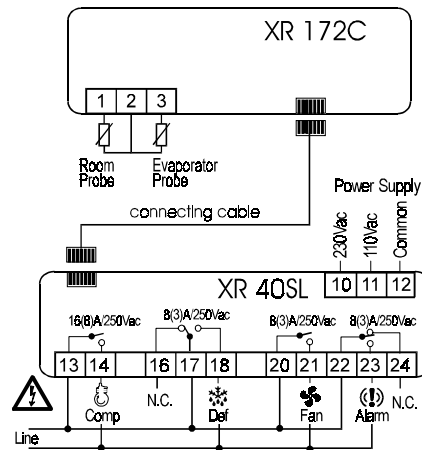
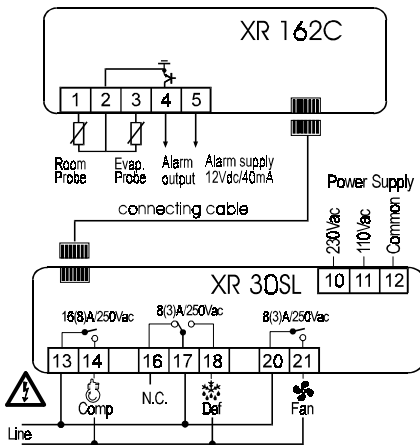
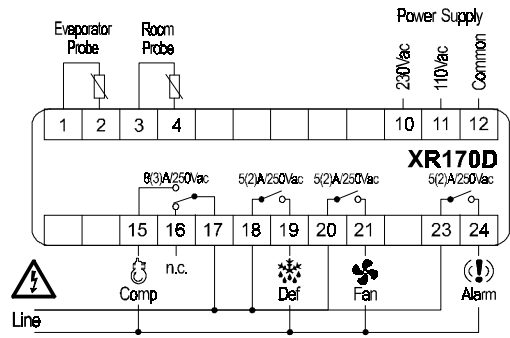
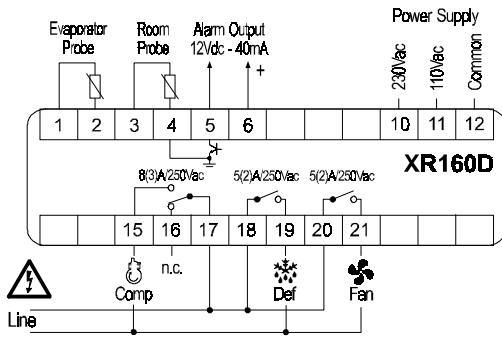

12. DEFAULT SETTING VALUES - STANDARD MODELS

PARAMETER	RANGE	LEVEL	DEFAULT °C/°F
Set	LS ÷ US	Pr1	-5/0
HY	0,2÷12°C / 2÷120°F	Pr1	2/4
LS	-57 ÷ Set	Pr2	-30/-22
US	Set ÷ 99°C / 196°F	Pr2	20/68
AC	0 ÷ 30	Pr2	1
ALC	0 o 2=rel (0 ÷50); 1o 3=absolute	Pr2	0
ALU	0÷50°C or 90°F /ALL ÷ 99°C / 196°F	Pr2	10/20
ALL	0÷50°C or 90°F / -57÷ ALU	Pr2	10/20
ALd	0 ÷ 120	Pr2	15
dAO	0 ÷ 720	Pr2	90/180
OdS	0÷120	Pr2	1
CCt	0 ÷ 990	Pr2	240
dAF	0 ÷ 120	Pr2	120
IdF	1 ÷ 120	Pr2	6
dSd	1 ÷ 120	Pr2	0
MdF	0 ÷ 120	Pr2	30
dtE	-57 ÷50°C o 196°F	Pr2	8/46
dFd	0=Real, 1=Start, 2=Set, 3=dEF	Pr2	1
dAd	0 ÷ 120	Pr2	30
tdF	0=Eletrical, 1=Hot gas (Long Time); 2= Relay OFF; 3=Relay ON (Short time)	Pr2	0
EdF	0=Not present, 1= Evap. Probe present	Pr2	1
Fdt	0 ÷ 120	Pr2	0
dPO	0=Immediately - 1=Normal	Pr2	1
FnC	OFF during defrost: 0=with compressor; 1=Continuously ON during defrost: 2=with compressor; 3=Continuously; 4=As 2° compressor	Pr2	1

PARAMETER	RANGE	LEVEL	DEFAULT °C/°F
FSt	-60 ÷ 50°C / 122°F	Pr2	2/35
Fnd	0 ÷ 120	Pr2	10
Ot	-12÷12°C; -120÷120°F	Pr2	0
OE	-12÷12°C; -120÷120°F	Pr2	0
CF	0=°Celsius 1=°Fahrenheit	Pr2	0/1
CO _n	0 ÷ 120	Pr2	15
COF	0 ÷ 120	Pr2	30

Dixell s.r.l.

Z.I. Via dell'Industria, 27 - 32010 Pieve d'Alpago (BL) ITALY

tel. +39 - 0437 - 98 33 - fax +39 - 0437 - 98 93 13

<http://www.dixell.com> E-mail: dixell@dixell.com